

# Installation, Operation, and Maintenance

## Split System Air Conditioners Odyssey™

R-22 Dry Charge

Cooling Condenser — 7.5, 10, 15 and 20 Tons

(60 Hz)

TTA0902\*A

TTA1202\*A

TTA1802\*D

TTA2402\*D

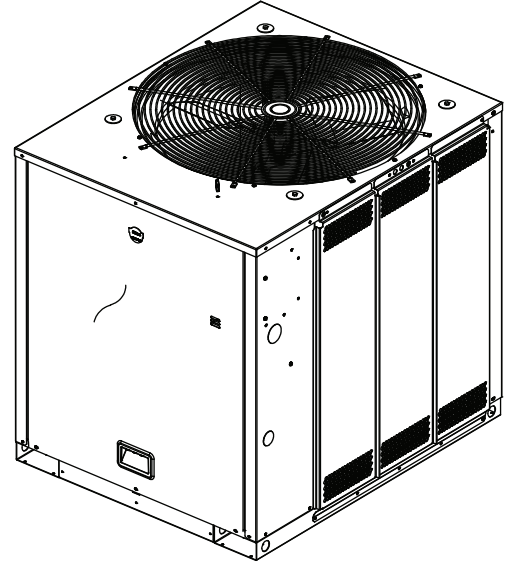

### ▲ SAFETY WARNING

Only qualified personnel should install and service the equipment. The installation, starting up, and servicing of heating, ventilating, and air-conditioning equipment can be hazardous and requires specific knowledge and training. Improperly installed, adjusted or altered equipment by an unqualified person could result in death or serious injury. When working on the equipment, observe all precautions in the literature and on the tags, stickers, and labels that are attached to the equipment.

July 2018

SS-SVX12G-EN

**IR** Ingersoll Rand.

# Introduction

Read this manual thoroughly before operating or servicing this unit.

## Warnings, Cautions, and Notices

Safety advisories appear throughout this manual as required. Your personal safety and the proper operation of this machine depend upon the strict observance of these precautions.

The three types of advisories are defined as follows:



Indicates a potentially hazardous situation which, if not avoided, could result in death or serious injury.



Indicates a potentially hazardous situation which, if not avoided, could result in minor or moderate injury. It could also be used to alert against unsafe practices.

**NOTICE**

Indicates a situation that could result in equipment or property-damage only accidents.

## Important Environmental Concerns

Scientific research has shown that certain man-made chemicals can affect the earth's naturally occurring stratospheric ozone layer when released to the atmosphere. In particular, several of the identified chemicals that may affect the ozone layer are refrigerants that contain Chlorine, Fluorine and Carbon (CFCs) and those containing Hydrogen, Chlorine, Fluorine and Carbon (HCFCs). Not all refrigerants containing these compounds have the same potential impact to the environment. Trane advocates the responsible handling of all refrigerants-including industry replacements for CFCs and HCFCs such as saturated or unsaturated HFCs and HCFCs.

## Important Responsible Refrigerant Practices

Trane believes that responsible refrigerant practices are important to the environment, our customers, and the air conditioning industry. All technicians who handle refrigerants must be certified according to local rules. For the USA, the Federal Clean Air Act (Section 608) sets forth the requirements for handling, reclaiming, recovering and recycling of certain refrigerants and the equipment that is used in these service procedures. In addition, some states or municipalities may have additional requirements that must also be adhered to for responsible management of refrigerants. Know the applicable laws and follow them.

### ⚠ WARNING

#### Proper Field Wiring and Grounding Required!

Failure to follow code could result in death or serious injury.

All field wiring **MUST** be performed by qualified personnel. Improperly installed and grounded field wiring poses **FIRE** and **ELECTROCUTION** hazards. To avoid these hazards, you **MUST** follow requirements for field wiring installation and grounding as described in **NEC** and your local/state/national electrical codes.

### ⚠ WARNING

#### Personal Protective Equipment (PPE) Required!

Failure to wear proper PPE for the job being undertaken could result in death or serious injury. Technicians, in order to protect themselves from potential electrical, mechanical, and chemical hazards, **MUST** follow precautions in this manual and on the tags, stickers, and labels, as well as the instructions below:

- Before installing/servicing this unit, technicians **MUST** put on all PPE required for the work being undertaken (Examples; cut resistant gloves/sleeves, butyl gloves, safety glasses, hard hat/bump cap, fall protection, electrical PPE and arc flash clothing). **ALWAYS** refer to appropriate Material Safety Data Sheets (MSDS)/Safety Data Sheets (SDS) and OSHA guidelines for proper PPE.
- When working with or around hazardous chemicals, **ALWAYS** refer to the appropriate MSDS/SDS and OSHA/GHS (Global Harmonized System of Classification and Labelling of Chemicals) guidelines for information on allowable personal exposure levels, proper respiratory protection and handling instructions.
- If there is a risk of energized electrical contact, arc, or flash, technicians **MUST** put on all PPE in accordance with OSHA, NFPA 70E, or other country-specific requirements for arc flash protection, **PRIOR** to servicing the unit. **NEVER PERFORM ANY SWITCHING, DISCONNECTING, OR VOLTAGE TESTING WITHOUT PROPER ELECTRICAL PPE AND ARC FLASH CLOTHING. ENSURE ELECTRICAL METERS AND EQUIPMENT ARE PROPERLY RATED FOR INTENDED VOLTAGE.**

**⚠ WARNING****Follow EHS Policies!**

Failure to follow instructions below could result in death or serious injury.

- All Ingersoll Rand personnel must follow Ingersoll Rand Environmental, Health and Safety (EHS) policies when performing work such as hot work, electrical, fall protection, lockout/tagout, refrigerant handling, etc. All policies can be found on the [BOS site](#). Where local regulations are more stringent than these policies, those regulations supersede these policies.
- Non-Ingersoll Rand personnel should always follow local regulations.

**⚠ WARNING****Refrigerant under High Pressure!**

Failure to follow instructions below could result in an explosion which could result in death or serious injury or equipment damage.

System contains refrigerant under high pressure. Recover refrigerant to relieve pressure before opening the system. See unit nameplate for refrigerant type. Do not use non-approved refrigerants, refrigerant substitutes, or refrigerant additives.

## Copyright

This document and the information in it are the property of Trane, and may not be used or reproduced in whole or in part without written permission. Trane reserves the right to revise this publication at any time, and to make changes to its content without obligation to notify any person of such revision or change.

## Trademarks

All trademarks referenced in this document are the trademarks of their respective owners.

## Revision History

- Configure to Order model number structure has been released and is now reflected in the model structure. All referenced model numbers have been updated to reflect this.
- Wiring matrix has been updated.
- Please note the Installation checklist has been moved to the Pre-Installation section.
- Minor running edits included.

# Table of Contents

Model Number Description .....	5	Electromechanical Controls .....	20
Cooling Condenser .....	5	Field Wiring .....	21
General Information .....	6	Refrigerant Circuit .....	22
Unit Description .....	6	Charging Charts and Superheat .....	23
Pre-Installation .....	7	Pre-Start .....	24
Unit Inspection .....	7	Control Circuit Features .....	24
Inspection Checklist .....	7	Discharge Temperature Limit	
Testing for Leaks .....	7	(DTL) .....	24
Lifting Recommendations .....	7	Low Outdoor Ambient Cooling .....	24
Clearances .....	7	Evaporator Defrost Control	
Unit Mounting .....	8	(EDC) .....	24
Structural Preparation .....	8	Low Pressure Cut-Out (LPCO) .....	24
Rooftop Mounting .....	8	High Pressure Cut-Out (HPCO) .....	24
Ground Level Mounting .....	8	Internal Overload Protector	
Installation Checklist .....	8	(IOL) .....	24
Refrigerant Piping .....	8	Startup .....	25
Electrical Wiring .....	9	Electromechanical Controls .....	25
Dimensional Data .....	10	General .....	25
Weights .....	14	Evaporator Fan (Indoor Supply	
Cooling Condenser .....	14	Air) .....	25
Installation .....	15	Cooling Mode .....	25
Refrigerant Piping Guidelines .....	15	Maintenance .....	26
Refrigerant Piping Procedures (Outdoor		Monthly .....	26
Units) .....	16	Annually (Cooling Season) .....	26
Refrigerant Piping Procedures (Indoor		Coil Cleaning .....	26
Unit) .....	17	Microchannel (MCHE) Coils .....	26
Leak Check .....	17	Maintenance Log .....	28
System Evacuation .....	18	Wiring Diagram Matrix .....	29
Insulating and Isolating Refrigerant		Warranty .....	30
Lines .....	18	For Commercial Unitary Equipment	
Refrigerant Charging Procedure .....	18	Rated Under 20 Tons and Related	
Charging Levels .....	19	Accessories .....	30
Liquid Charging .....	19	Basic Warranty .....	30
Electrical Wiring .....	20	Exclusions and Limitations .....	30
Unit Power Supply .....	20	Commercial Equipment Rated 20 Tons	
Low Voltage Wiring .....	20	and Larger and Related Accessories	
		(Parts Only) .....	30
		Exclusions And Limitations .....	31

# Model Number Description

## Cooling Condenser

### Digit 1-3 – Unit Function

**TTA** = Split System Cooling

### Digit 4-6 – Tonnage

**090** = 7.5 Tons (60Hz)

**120** = 10 Tons (60Hz)

**180** = 15 Tons (60Hz)

**240** = 20 Tons (60Hz)

### Digit 7 – Refrigerant

**2** = R-22

### Digit 8 – Voltage

**3** = 208-230VAC - 3 PH (60Hz)

**4** = 460VAC - 3 PH (60Hz)

### Digit 9 – Refrigeration Circuit/Stage

**A** = 1 Compressor/1 Line/1 Stage (Single)

**D** = 2 Compressors/2 Line/2 Stage (Duals)

### Digit 10 – Major Design Sequence

**B** = Rev B

### Digit 11 – Minor Design Sequence

**A** = Rev A

### Digit 12-13 – Service Digits

**00** = 00

### Digit 14 – Efficiency Generation

**A** = Generation A

### Digit 15 – Controls

**E** = Electromechanical

### Digit 16 – None

**0** = None

### Digit 17 – Coil Protection

**0** = Standard Coil

### Digit 18-20 – None

**0** = None

### Digit 21 – Communications Options

**0** = No Option

### Digit 22-40 – None

**0** = None

# General Information

This manual describes proper installation, operation, and maintenance procedures for air-cooled systems. By carefully reviewing the information within this manual and following the instructions, the risk of improper operation and/or component damage will be minimized. It is important that periodic maintenance be performed to help assure trouble free operation. Should equipment failure occur, contact a qualified service organization with qualified, experienced HVAC technicians to properly diagnose and repair this equipment.

**Important:** *All phases of this installation must comply with the NATIONAL, STATE & LOCAL CODES. In addition to local codes, the installation must conform with National Electric Code -ANSI/NFPA NO. 70 LATEST REVISION.*

Any individual installing, maintaining, or servicing this equipment must be properly trained, licensed and qualified.

Installation procedures should be performed in the sequence that they appear in this manual. Do not destroy or remove the manual from the unit. The manual should remain weather-protected with the unit until all installation procedures are complete.

**Note:** *It is not the intention of this manual to cover all possible variations in systems that may occur or to provide comprehensive information concerning every possible contingency that may be encountered during an installation. If additional information is required or if specific problems arise that are not fully discussed in this manual, contact your local sales office.*

Use the “[Installation Checklist](#),” p. 8 provided in this manual to verify that all necessary installation procedures have been completed. Do not use the checklist as a substitute for reading the information contained in the manual. Read the entire manual before beginning installation procedures.

## Unit Description

These condensers come with single and dual compressor options. Single compressor outdoor units feature a single refrigeration circuitry, requiring only one set of refrigerant lines. Dual compressor/dual circuit models give true stand-by protection; if one compressor fails, the second will automatically start-up. During light load conditions, only one compressor will operate to save energy.

# Pre-Installation

## Unit Inspection

Inspect material carefully for any shipping damage. If damaged, it must be reported to, and claims made against the transportation company. Compare the information that appears on the unit nameplate with ordering and submittal data to ensure the proper unit was shipped. Available power supply must be compatible with electrical characteristics specified on component nameplates. Replace damaged parts with authorized parts only.

## Inspection Checklist

To protect against loss due to damage incurred in transit, complete the following checklist upon receipt of the unit.

- Inspect individual pieces of the shipment before accepting the unit. Check for obvious damage to the unit or packing material.
- Inspect the unit for concealed damage before it is stored and as soon as possible after delivery. Concealed damage must be reported within 15 days. If concealed damage is discovered, stop unpacking the shipment. Do not remove damaged material from the receiving location. Take photos of the damage if possible. The owner must provide reasonable evidence that the damage did not occur after delivery.
- Notify the carrier's terminal of damage immediately by phone and by mail. Request an immediate joint inspection of the damage by the carrier and the consignee.
- Notify the sales representative and arrange for repair. Do not repair the unit until the damage is inspected by the carrier's representative.

## Testing for Leaks

All units are shipped with a holding charge of nitrogen in each circuit and should be leak tested before installation.

1. Remove the access panel.
2. Locate the liquid line or suction line access valve for each circuit.
3. Install gauges to determine if the circuits are still pressurized. If not, the charge has escaped and should be repaired as required to obtain a leak-free circuit.

## Lifting Recommendations

### ⚠ WARNING

#### Improper Unit Lift!

Failure to properly lift unit in a LEVEL position could result in unit dropping and possibly crushing operator/technician which could result in death or serious injury, and equipment or property-only damage.

Test lift unit approximately 24 inches (61 cm) to verify proper center of gravity lift point. To avoid dropping of unit, reposition lifting point if unit is not level.

### NOTICE

#### Equipment Damage!

Use spreader bars to prevent straps from damaging the unit. Install the bars between lifting straps, both underneath the unit and above the unit to prevent the straps from crushing the unit cabinet or damaging the finish.

Before preparing the unit for lifting, estimate the approximate center of gravity for lifting safety. Because of placement of internal components, the unit weight may be unevenly distributed. See "Weights," p. 14 for approximate unit weights.

The crated unit can be moved using a forklift of suitable capacity. For lifting the unit, attach lifting straps or slings securely to the lifting holes at each corner (see unit drawings in "Weights," p. 14). Use spreader bars to protect the unit casing from damage. Test lift the unit to determine proper balance and stability.

## Clearances

Provide enough space around the unit to allow unrestricted access to all service points. Refer to the "Dimensional Data," p. 10 for unit dimensions and minimum required service and free air clearances. Observe the following points to ensure proper unit operation.

1. Do not install the unit under a low overhang. Condenser discharge must not be restricted—refer to notes in "Dimensional Data drawings," p. 10.  
*Important: Do not obstruct condenser discharge air. This can result in warm air recirculation through the coil.*
2. Do not locate the unit in a position where runoff water can fall into the fan discharge openings.
3. Condenser intake air is supplied from three or four sides of the unit. Adhere to the minimum required clearances given in unit dimensional drawings (see "Dimensional Data," p. 10).

## Unit Mounting

### ⚠ WARNING

#### Risk of Roof Collapsing!

Failure to ensure proper structural roof support could cause the roof to collapse, which could result in death or serious injury and property damage.

Confirm with a structural engineer that the roof structure is strong enough to support the combined weight of the roof curb, the unit, and any accessories.

### Structural Preparation

### NOTICE

#### Roof Damage!

System contains oil and refrigerant under high pressure. Roofs should be protected from exposure to oils and refrigerant in the system. If rooftop is not protected, damage to the roof may occur.

*Important: Refer to local building codes for proper installation. All installation must comply with local building codes.*

### Rooftop Mounting

If the unit will be roof mounted, determine for certain that the structure is strong enough to support the unit and any required accessories, see "Weights," p. 14. The unit should be elevated on a level, field fabricated four-inch steel or wood 4" x 4" mounting frame. Complete the frame and secure it into position before lifting the unit to the roof. The mounting frame must support a minimum of three of the unit's four sides and should span roof supports to distribute the load on the roof.

Figure 1. Roof mounted unit

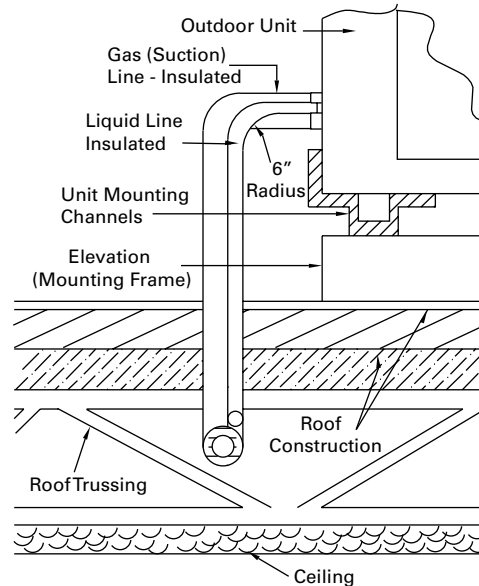

### Ground Level Mounting

For ground level installation, the unit base should be adequately supported and hold the unit near level. The installation must meet the guidelines set forth in local codes. The support should extend two inches beyond the unit base channels at all points. The unit and support must be isolated from any adjacent structure to prevent possible noise or vibration problems. Any ground level location must comply with required clearances given in the unit dimensional drawings (see "Dimensional Data," p. 10).

### Installation Checklist

Complete this checklist once the unit is installed to verify that all recommended procedures have been accomplished before starting the system. Do not operate the system until all items covered by this checklist are complete.

- Inspect unit location for proper required service clearances.
- Inspect unit location for proper free air clearances.
- Inspect unit location for secure, level mounting position.

### Refrigerant Piping

- Properly sized/constructed liquid and suction lines connected to stubs at both the indoor and outdoor units?
- Insulated the entire suction line?
- Insulated portions of liquid line exposed to extremes in temperature?
- Performed initial leak test?



- Evacuated each refrigerant circuit to 500 microns?
- Charged each circuit with proper amount of R-22?

### **Electrical Wiring**

- Provided unit power wiring (with disconnect) to
- proper terminals in the unit control section?
- Installed system indoor thermostat?
- Installed system low voltage interconnecting wiring to proper terminals of outdoor unit, indoor unit and system thermostat?

# Dimensional Data

Figure 2. Height, width and depth measurements

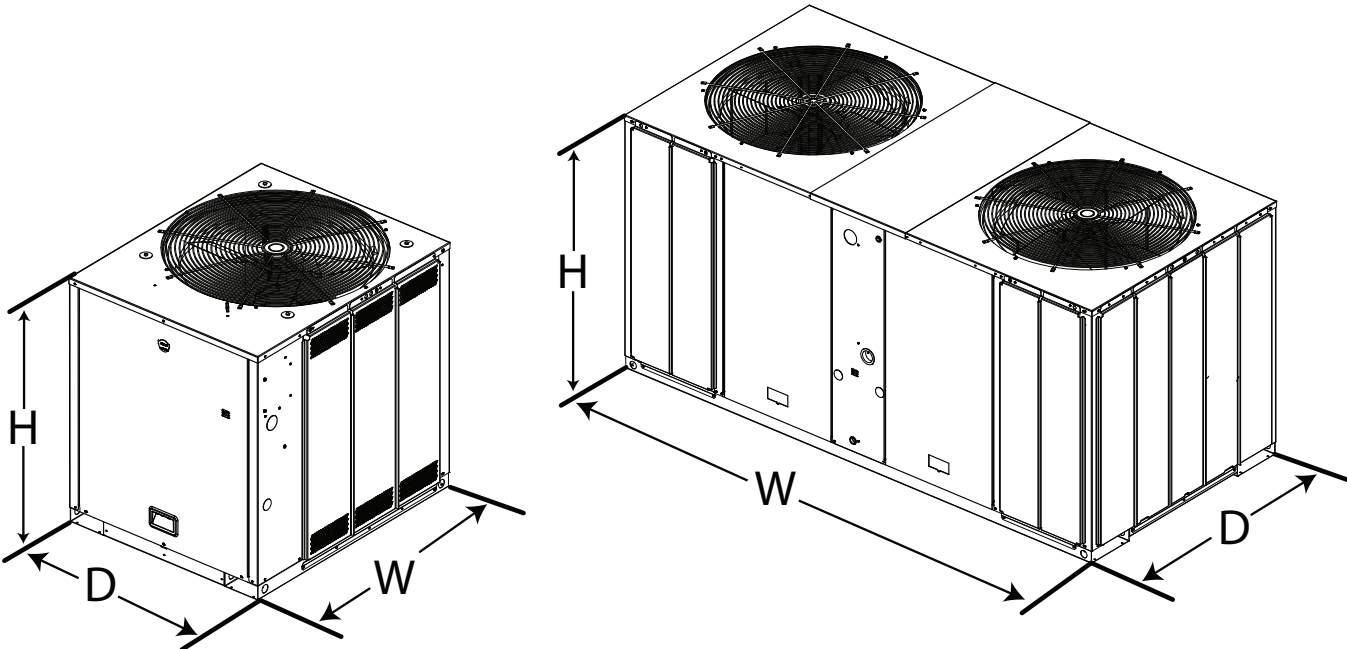

	H - in. (mm)	W - in. (mm)	D - in. (mm)
TTA0902*A	46.1 (1171)	45 (1143)	38 (965.2)
TTA1202*A	46.1 (1171)	55 (1397)	42 (1067)
TTA1802*D, 2402*D	52.1 (1323)	96 (2438)	48 (1219)

*Note: Full dimensional data available on next pages.*

Figure 3. 7.5 ton condensing unit, single compressor, microchannel

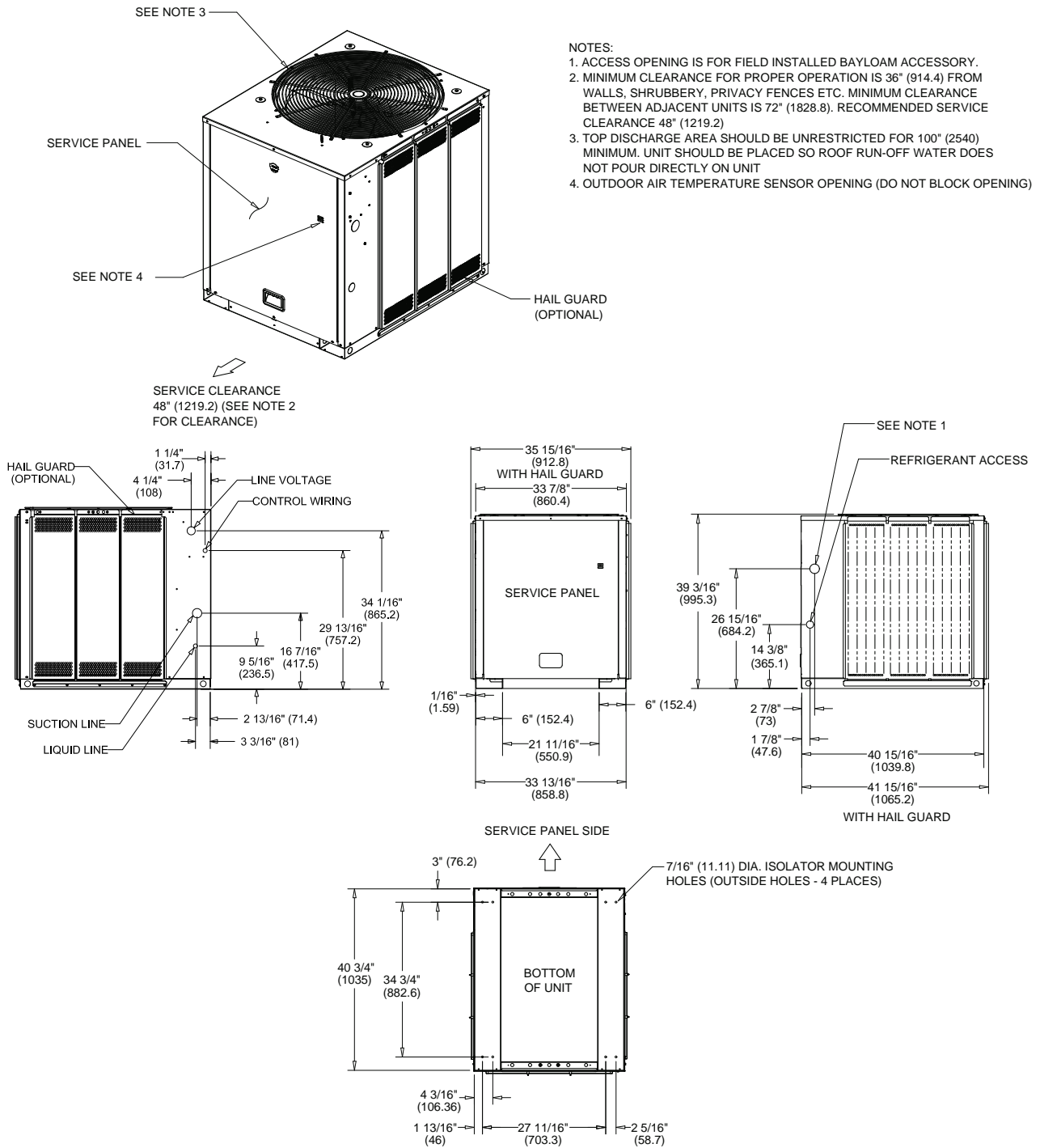

# Dimensional Data

**Figure 4. 10 ton condensing unit, single compressor, microchannel**

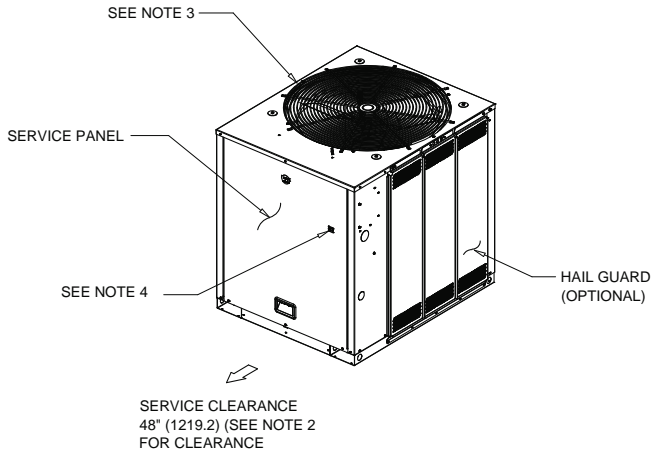

- NOTES:
1. ACCESS OPENING IS FOR FIELD INSTALLED BAYLOAM ACCESSORY.
  2. MINIMUM CLEARANCE FOR PROPER OPERATION IS 36" (914.4) FROM WALLS, SHRUBBERY, PRIVACY FENCES ETC. MINIMUM CLEARANCE BETWEEN ADJACENT UNITS IS 72" (1828.8). RECOMMENDED SERVICE CLEARANCE 48" (1219.2)
  3. TOP DISCHARGE AREA SHOULD BE UNRESTRICTED FOR 100" (2540) MINIMUM. UNIT SHOULD BE PLACED SO ROOF RUN-OFF WATER DOES NOT POUR DIRECTLY ON UNIT
  4. OUTDOOR AIR TEMPERATURE SENSOR OPENING (DO NOT BLOCK OPENING)

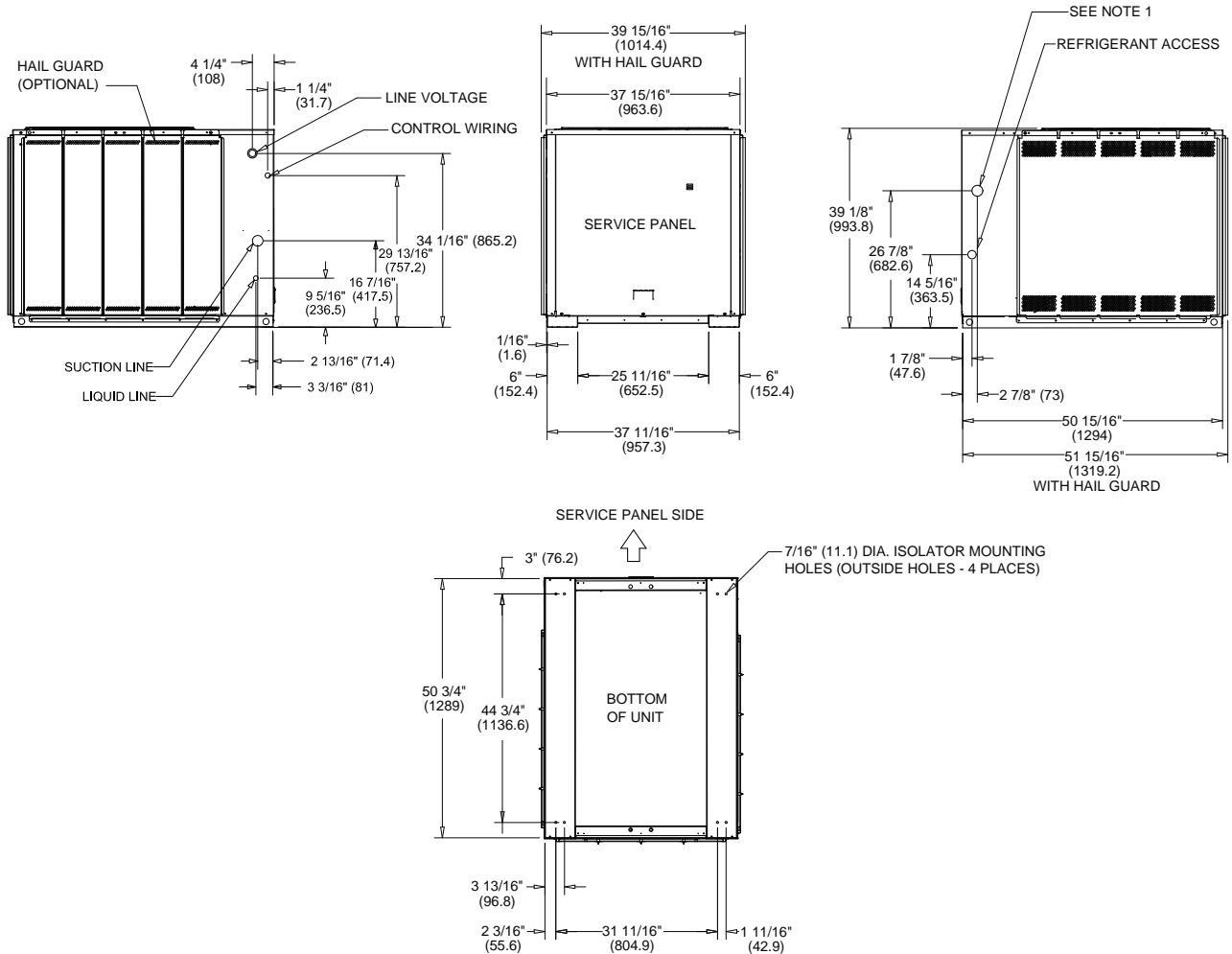
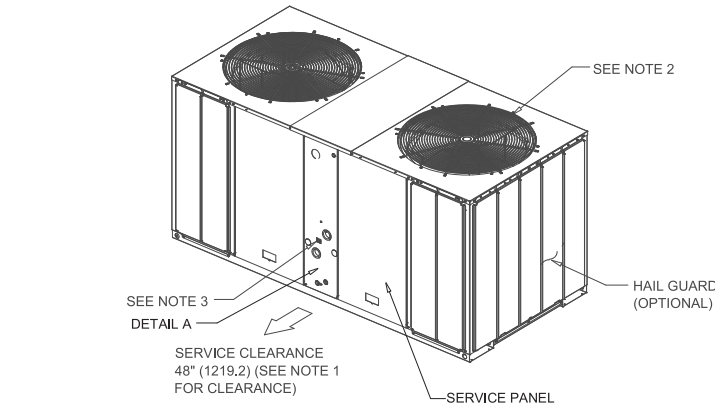
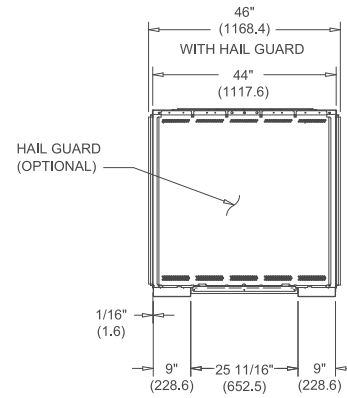
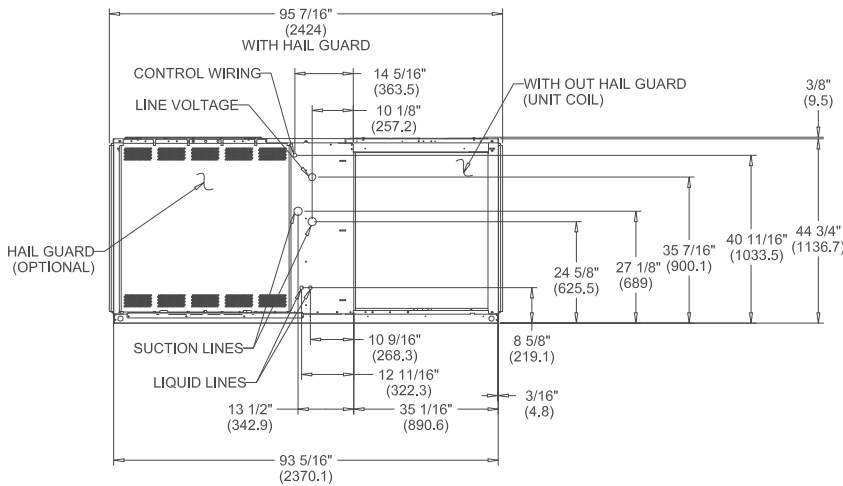

Figure 5. 15–20 ton condensing unit, dual compressor, microchannel



- NOTES:
1. MINIMUM CLEARANCE FOR PROPER OPERATION IS 36" (914.4) FROM WALLS, SHRUBBERY, PRIVACY FENCES ETC. MINIMUM CLEARANCE BETWEEN ADJACENT UNITS IS 72" (1828.8). RECOMMENDED SERVICE CLEARANCE 48" (1219.2)
  2. TOP DISCHARGE AREA SHOULD BE UNRESTRICTED FOR 100" (2540) MINIMUM. UNIT SHOULD BE PLACED SO ROOF RUN-OFF WATER DOES NOT POUR DIRECTLY ON UNIT
  3. OUTDOOR AIR TEMPERATURE SENSOR OPENING (DO NOT BLOCK OPENING)



OPTIONAL REAR ACCESS  
DIMENSIONAL DETAIL

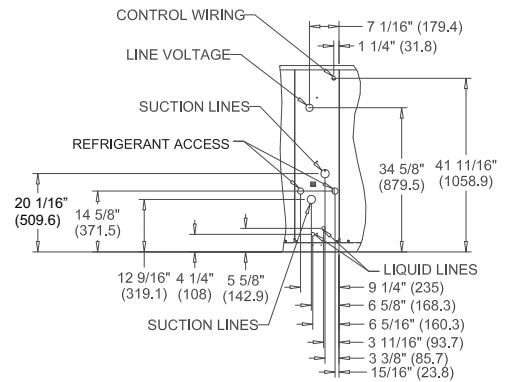
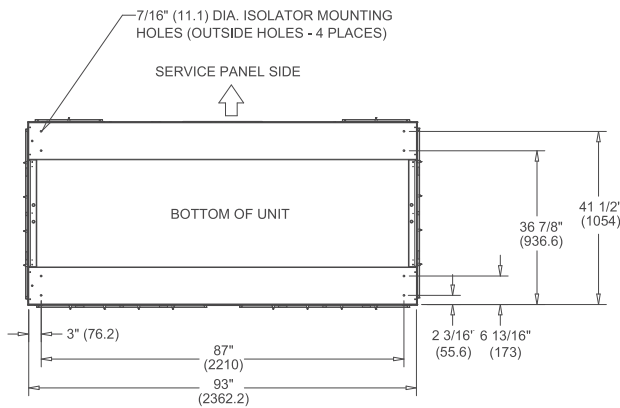

FRONT DETAIL A  
DIMENSIONAL DETAIL

# Weights

## Cooling Condenser

Table 1. TTA unit and corner weights – lbs (60 Hz)

Tons	Model No.	Shipping Max (lbs)	Net Max (lbs)	Corner Weights			
				1	2	3	4
7.5	TTA0902*A	328	280	73	89	51	67
10	TTA1202*A	405	329	107	84	60	77
15	TTA1802*D	776	661	141	228	112	180
20	TTA2402*D	922	756	180	265	122	190

Figure 6. TTA0902\*A, 1202\*A

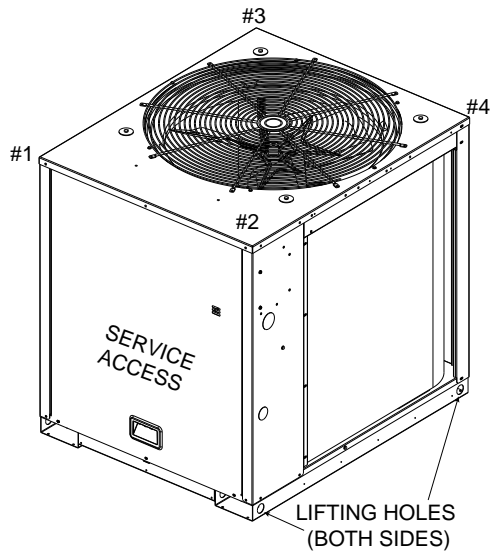
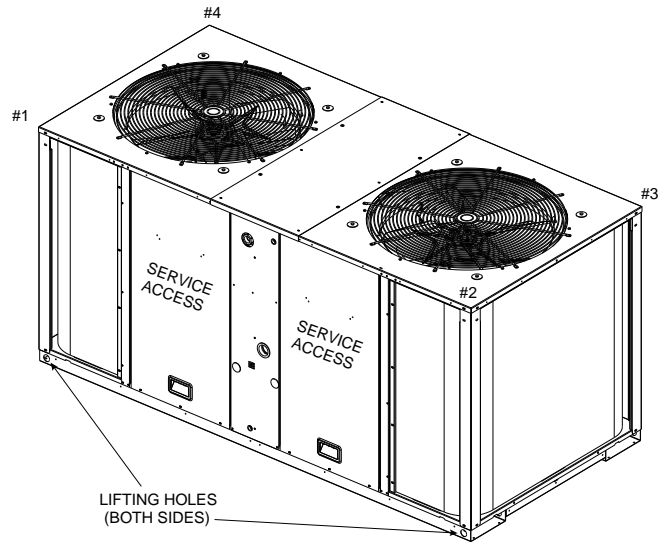

Figure 7. TTA1802\*D, 2402\*D



# Installation

## Refrigerant Piping Guidelines

**Figure 8. Allowable elevation difference: TTA *above* indoor unit**

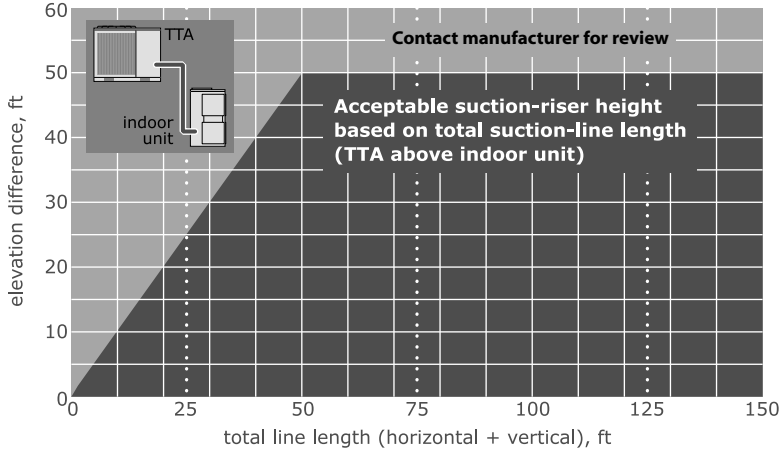

**Figure 9. Allowable elevation difference: TTA or TWA *below* indoor unit**

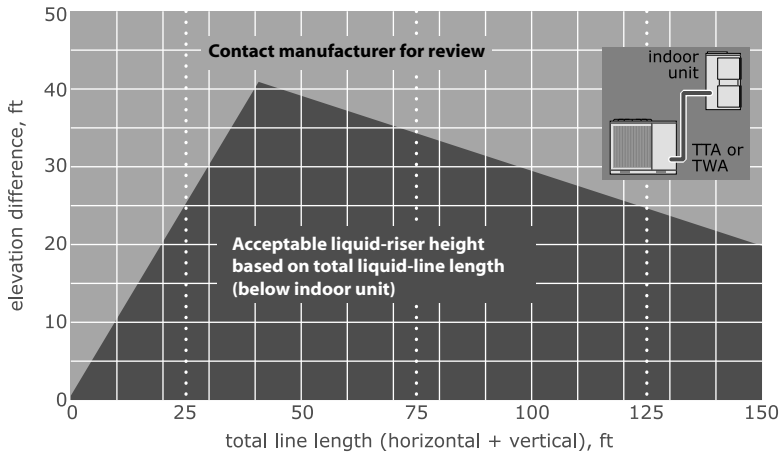

**Note:** Route refrigerant piping for minimum linear length, minimum number of bends and fittings.

## Refrigerant Piping Procedures (Outdoor Units)

### ⚠ WARNING

#### Refrigerant under High Pressure!

Failure to follow instructions below could result in an explosion which could result in death or serious injury or equipment damage. System contains refrigerant under high pressure. Recover refrigerant to relieve pressure before opening the system. See unit nameplate for refrigerant type. Do not use non-approved refrigerants, refrigerant substitutes, or refrigerant additives.

### ⚠ WARNING

#### Explosion Hazard!

Failure to follow instructions below could result in an explosion which could result in death or serious injury, and equipment damage. NEVER bypass system safeties in order to pump down the unit component's refrigerant into the microchannel heat exchanger (MCHE) coil. Do NOT depress the compressor contactor since it effectively bypasses the high-pressure control.

Each unit ships with a holding charge of dry nitrogen. The nitrogen should be removed and the entire system evacuated (at the proper time) to avoid possible contamination.

1. Remove the compressor service access panel.
2. Locate the liquid and suction line access valves. Check that the piping connection stubs (Figure 10, p. 16) line up properly with the holes in the unit cabinet.

Figure 10. Outdoor units - refrigerant piping (with dry nitrogen)

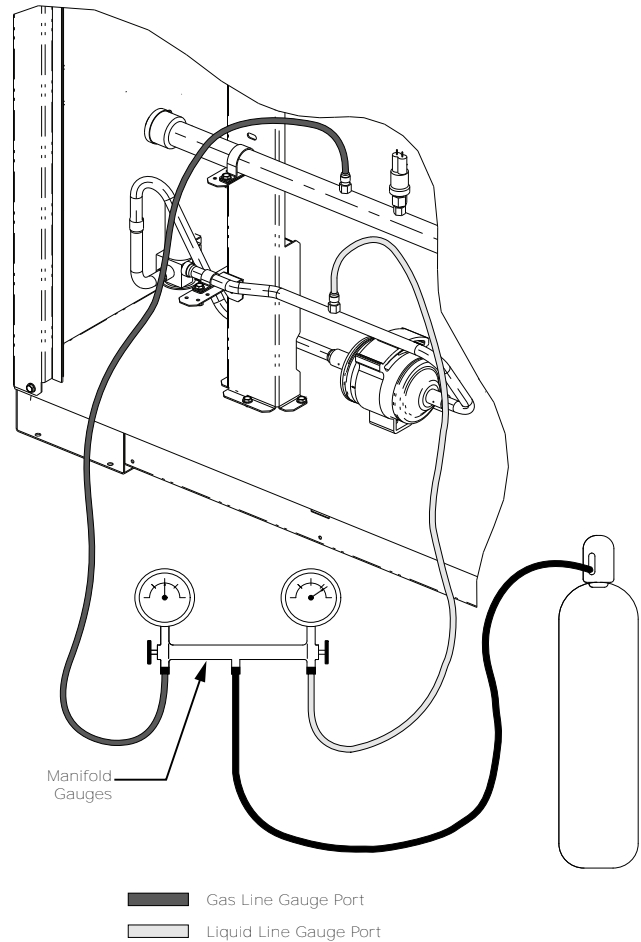

3. Install gauges to determine if the circuits are still pressurized. If not, the charge has escaped and should be repaired as required to obtain a leak-free circuit. If the circuits are still pressurized, use the gauges to slowly release the nitrogen charge to the atmosphere and remove both seal caps from the outdoor unit connection stubs.

### NOTICE

#### System Component Damage!

Do not remove the seal caps from refrigerant connections until prepared to braze refrigerant lines to the connections. Excessive exposure to atmosphere (> 5 min.) may allow moisture or dirt to contaminate the system, damaging valve seals and causing ice formation in system components.



**⚠ WARNING****Explosion Hazard and Deadly Gases!**

Failure to follow all proper safe refrigerant handling practices could result in death or serious injury.

Never solder, braze or weld on refrigerant lines or any unit components that are above atmospheric pressure or where refrigerant may be present. Always remove refrigerant by following the guidelines established by the EPA Federal Clean Air Act or other state or local codes as appropriate. After refrigerant removal, use dry nitrogen to bring system back to atmospheric pressure before opening system for repairs. Mixtures of refrigerants and air under pressure may become combustible in the presence of an ignition source leading to an explosion. Excessive heat from soldering, brazing or welding with refrigerant vapors present can form highly toxic gases and extremely corrosive acids.

- Cut, fit and braze tubing, starting at the outdoor unit and work toward the indoor unit.

**Note:** Use long radius ells for all 90° bends.

All brazing should be done using a 2 to 3 psig dry nitrogen purge flowing through the pipe being brazed, see [Figure 10, p. 16](#).

**NOTICE****System Component Damage!**

Install a regulating valve between the nitrogen source and the gauge manifold. Unregulated pressure can damage system components.

**NOTICE****System Component Damage!**

Wet-wrap all valves and protect painted surfaces from excessive heat. Heat can damage system components and the unit finish.

- Shut off nitrogen supply. Shut off the manifold valve for the line that is connected to the suction line access valve. Disconnect the line from the access valve.

**Refrigerant Piping Procedures (Indoor Unit)**

Once liquid and suction lines are complete to the refrigerant connections on the indoor unit, remove the gauge port core(s) on the indoor unit connection stubs to release the dry nitrogen charge.

**NOTICE****Unit Damage!**

Do not apply heat to remove seal caps until the gauge port cores have been removed. If seal caps are intact, application of heat may generate excessive pressure in the unit and result in damage to the coil or expansion valve.

- Remove both seal caps from the indoor unit connection stubs.

**NOTICE****Unit Damage!**

Do not remove the seal caps from refrigerant connections until prepared to braze refrigerant lines to the connections.

- Turn on nitrogen supply. Nitrogen enters through the liquid line gauge port.
- Braze the liquid line connections.
- Open the gauge port on the suction line and then braze the gauge line to the connection stub. Nitrogen will bleed out the open gauge port on the suction line.
- Shut off nitrogen supply.

**Leak Check****⚠ WARNING****Explosion Hazard!**

Failure to follow these instructions could result in death or serious injury or equipment or property-only damage.

Use only dry nitrogen with a pressure regulator for pressurizing unit. Do not use acetylene, oxygen or compressed air or mixtures containing them for pressure testing. Do not use mixtures of a hydrogen containing refrigerant and air above atmospheric pressure for pressure testing as they may become flammable and could result in an explosion. Refrigerant, when used as a trace gas should only be mixed with dry nitrogen for pressurizing units.

**⚠ WARNING****Explosion Hazard!**

Failure to follow safe leak test procedures below could result in death or serious injury or equipment or property-only-damage.

**Never use an open flame to detect gas leaks. Use a leak test solution for leak testing.**

After the brazing operation of refrigerant lines to both the outdoor and indoor unit is completed, the field brazed connections must be checked for leaks. Pressurize the system through the access valve with

## Installation

dry nitrogen to 200 psi. Use soap bubbles or other leak-checking methods to ensure that all field joints are leak free. If not, release pressure, repair and repeat leak test.

### System Evacuation

1. After completion of leak check, evacuate the system.
2. Attach appropriate hoses from manifold gauge to gas and liquid line pressure taps.

**Note:** *Unnecessary switching of hoses can be avoided and complete evacuation of all lines leading to sealed system can be accomplished with manifold center hose and connecting branch hose to a cylinder of R-22 and vacuum pump.*

3. Attach center hose of manifold gauges to vacuum pump.

#### NOTICE

##### Operating Under Vacuum!

Failure to follow these instructions will result in compressor failure.

Do not operate or apply power to the compressor while under a vacuum.

4. Evacuate the system to hold a 500 micron vacuum.
5. Close off valve to vacuum pump and observe the micron gauge. If gauge pressure rises above 500 microns in one minute, then evacuation is incomplete or the system has a leak.
6. If vacuum gauge does not rise above 500 microns in 10 minutes, the evacuation should be complete.

#### NOTICE

##### Equipment Damage!

Charge with access port on the liquid line only.

7. With vacuum pump and micron gauge blanked off, open valve on R-22 cylinder and allow refrigerant pressure to build up to about 80 psig.
8. Close valve on the R-22 supply cylinder. Close valves on manifold gauge set and remove refrigerant charging hoses from liquid and gas gauge ports.
9. Leak test the entire system. Using proper procedures and caution, as described in the previous section, repair any leaks found and repeat the leak test.

## Insulating and Isolating Refrigerant Lines

Insulate the entire suction line with refrigerant piping insulation. Also insulate any portion of the liquid line exposed to temperature extremes. Insulate and isolate

liquid and suction lines from each other. Isolate refrigerant lines from the structure and any duct work.

#### Important:

1. *To prevent possible noise or vibration problems, be certain to isolate refrigerant lines from the building.*
2. *All suction and hot gas bypass piping (if installed) should be insulated from the termination in the air handler to the condensing unit cabinet entry. Failure to do so can cause condensate drip off and performance degradation.*
3. *Prior to starting a unit, it is advisable to have the approved oils available in the event oil needs to be added to the system.*

#### NOTICE

##### Equipment Damage!

This is POE oil, which readily absorbs moisture. Always use new oil and never leave containers open to atmosphere while not in use.

Table 2. R-22 TTA approved oils

Unit Model Number	Approved Oils
TTA0902*A, TTA1202*A, TTA1802*B, TTA2402*B	Trane Oil Part Number OIL00094 (1 quart container)

For units equipped with compressors containing site glasses, the oil level must be visible through the sight glass when the compressor is running under stabilized conditions and a few minutes after the compressor has stopped.

## Refrigerant Charging Procedure

If charging by weight, refer to for starting charge. If refrigerant adjustments are needed because of length of line, refer to the Charging Charts and Superheat values in the unit's Service Facts.

Charge by weight through the gauge port on the liquid line.

**Notes:**

- R-22 should only be charged in the liquid state.
- When possible, always charge the refrigerant into the liquid line of the unit.
- If the entire charge can't be charged into the liquid line, the balance of the unit charge can be metered through a charging manifold set as liquid — preferably through a schrader valve into the suction line to the compressor — only while the compressor is running.
- Check and adjust superheat using the superheat table in the unit's Service Facts, then re-check charging charts to determine if charge corrections are necessary.

**Note:** The compressor access panel must be installed when the unit is running and being charged. Manifold hoses must be routed through refrigerant gauge access hole(s). See "Dimensional Data," p. 10 for specific locations.

**NOTICE**

**Equipment Damage!**  
Never charge liquid refrigerant into the suction line of the unit with the compressor off.

**Figure 11. Outdoor units - refrigerant piping**

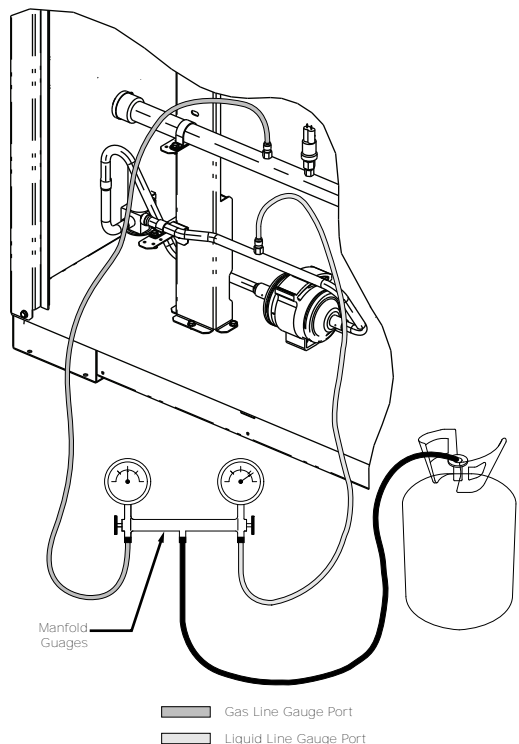

**Charging Levels**

**Liquid Charging**

This procedure is accomplished with the unit operating. Electrical connections must be complete. Do not proceed until the system is ready to operate.

**⚠ WARNING**

**Live Electrical Components!**  
Failure to follow all electrical safety precautions when exposed to live electrical components could result in death or serious injury. When it is necessary to work with live electrical components, have a qualified licensed electrician or other individual who has been properly trained in handling live electrical components perform these tasks.

1. Turn on power to the unit. Allow the system to run for 15 minutes to stabilize operating conditions.
2. Measure airflow across the indoor coil. Compare the measurements with the fan performance data in the Data/Submittal or Service Facts. Once proper airflow is established, compare discharge pressure and liquid temperature to the charging charts. Add or remove refrigerant (liquid only) as required to obtain correct discharge pressure and liquid temperature.
3. Check suction line superheat and condenser sub-cooling to ensure the unit is operating properly.
4. Disconnect all power to the unit.

**Important:** If the unit is charged and left without power until a later date, the crankcase heater should be energized for a minimum of 8 hours prior to powering the compressor(s).

**⚠ WARNING**

**Hazardous Voltage w/Capacitors!**  
Failure to disconnect power and discharge capacitors before servicing could result in death or serious injury. Disconnect all electric power, including remote disconnects and discharge all motor start/run capacitors before servicing. Follow proper lockout/tagout procedures to ensure the power cannot be inadvertently energized. For variable frequency drives or other energy storing components provided by Trane or others, refer to the appropriate manufacturer's literature for allowable waiting periods for discharge of capacitors. Verify with a CAT III or IV voltmeter rated per NFPA 70E that all capacitors have discharged. For additional information regarding the safe discharge of capacitors, see PROD-SVB06\*-EN.

5. Remove the charging system from the unit.



Field Wiring

Figure 13. Thermostat wiring for electromechanical units

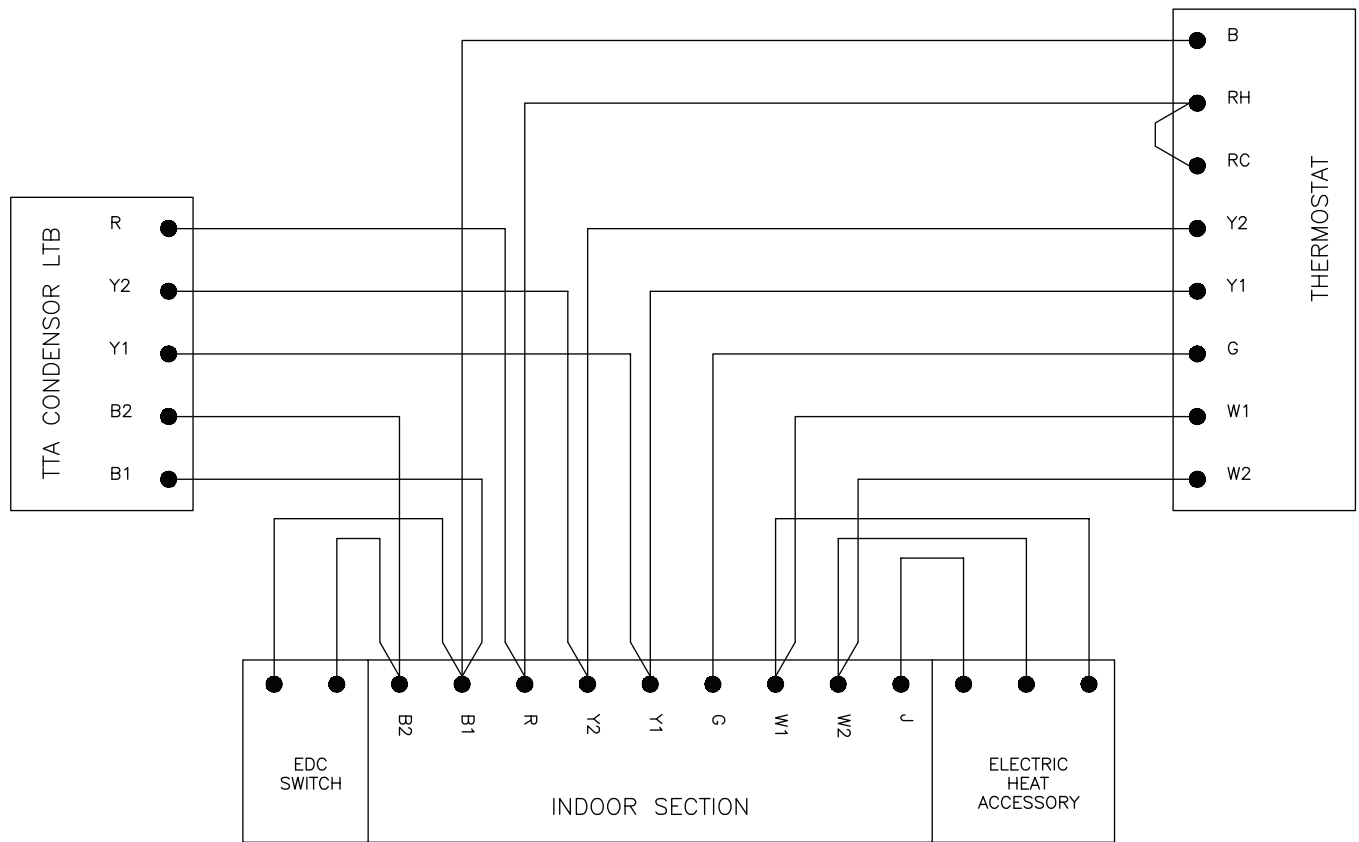

Refrigerant Circuit

Figure 14. Typical split system cooling refrigerant circuit – microchannel

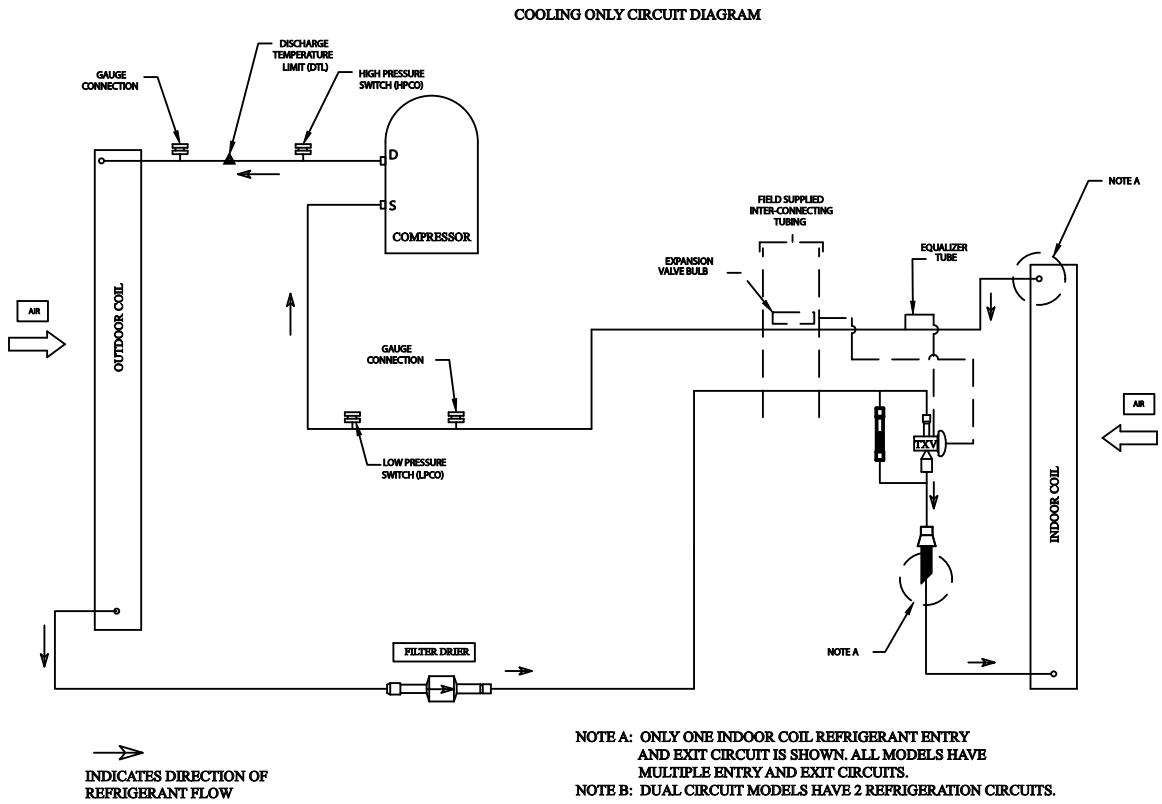

# Charging Charts and Superheat

Figure 15. TTA0902\*A charging curve

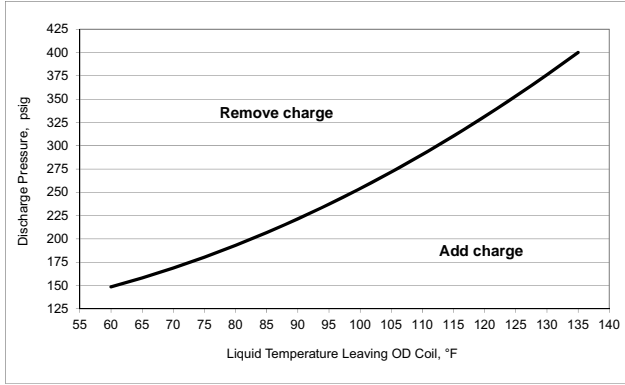

Figure 17. TTA1802\*D charging curve

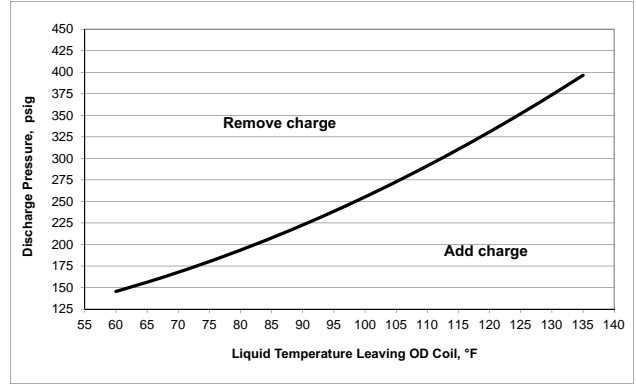

Figure 16. TTA1202\*A charging curve

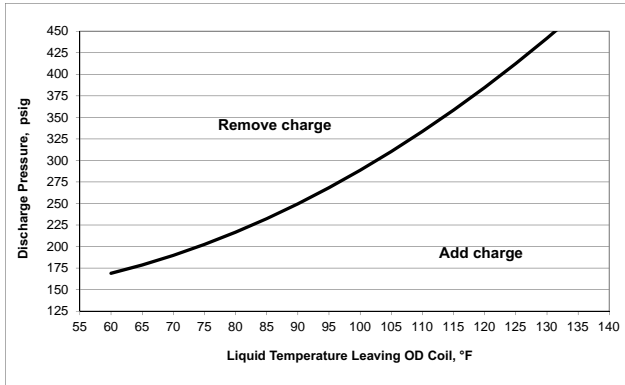

Figure 18. TTA2402\*D charging curve

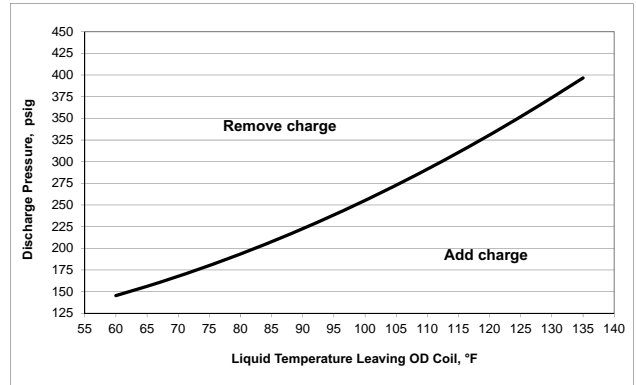

Table 3. TTA superheat with matched TWE air handler

Condenser	Air Handler	Cooling Superheat	
		Circuit 1	Circuit 2
TTA0902*A	TWE090A	12.8	—
TTA1202*A	TWE120A	15.5	—
TTA1802*D	TWE180B	18.4	18.4
TTA2402*D	TWE240B	15.2	15.2

**Notes:**

1. An adjustable TXV is provided for each circuit in the TWE and TWA models. If the application causes the superheat to deviate from the values shown above by more than 1 degree - after the system has achieved steady state - the TXV should be adjusted to provide the values shown as measured at the compressor.
2. The values given above have been tested and are approved for the matched sets shown. If an alternate combination is used, an expansion device should be used that provides 16-20°F degrees of superheat measured at the compressor.
3. Check and adjust superheat using this table, then compare with charging chart to determine if charge corrections are necessary.

# Pre-Start

## Control Circuit Features

*Note: Not all of these features may be required for your unit, check electrical schematic.*

### Discharge Temperature Limit (DTL)

The control's sensor is located on the discharge line. This device will shut off the compressor and the outdoor fan(s) if the discharge temperature exceeds the DTL setting. Once the discharge temperature has returned to normal, the compressor will cycle back on.

### Low Outdoor Ambient Cooling

The Evaporator Defrost Control is standard equipment on Air Handlers and will permit low ambient cooling down to 50°F. For cooling operation down to 0°F, use an Accessory Head Pressure Control on the outdoor unit.

### Evaporator Defrost Control (EDC)

This control is located in the Air Handler. The control's sensing tube is embedded vertically in the evaporator coil, near the center. This device will stop the compressor if the indoor coil temperature drops below its setting. The indoor air will still circulate across the coil bringing the temperature of the coil back up to the cut-in temperature of the evaporator defrost control.

### Low Pressure Cut-Out (LPCO)

This control's sensor is located in the suction (gas) line, near the compressor. This control will stop the

compressor and the outdoor fans if suction pressure drops below the Low Pressure Cut-Out setting. Once the suction pressure has returned to normal, the compressor and outdoor fans will cycle back on.

### High Pressure Cut-Out (HPCO)

This control's sensor is located in the discharge line. This device will shut off the compressor and the outdoor fan(s) if the discharge pressure exceeds the High Pressure Cut-Out's setting. Once the discharge pressure has returned to normal, the compressor will cycle back on.

## **⚠ WARNING**

### **Prevent Injury!**

**Due to agency safety requirements, no schrader core is to be installed beneath the HPCO. Removal of the HPCO without evacuating the system charge could cause injury and release of refrigerant.**

### Internal Overload Protector (IOL)

This device is embedded in the compressor. It will shut off the compressor if the discharge temperature of the compressor exceeds its design trip temperature.

*Note: The IOL will put the compressor back in operation once the compressor motor heat has dropped below the trip setting; however, a check of the refrigerant and electrical systems should be made to determine the cause and be corrected.*



# Startup

## Electromechanical Controls

The 24-volt, electromechanical controls feature a control transformer and contactor pressure lugs for power wiring. Once the unit is properly installed and pre-start procedures are complete, start the unit by turning the System Switch on the indoor thermostat to either **HEAT**, **COOL** or **AUTO**. The system should operate normally.

### **NOTICE**

#### **Equipment Damage!**

**Ensure the disconnect for the indoor air handler is closed before operating the system. Operating the outdoor unit without the indoor fan energized can cause unit trip-out on high pressure control and/or liquid flood back to the compressor.**

## General

Operation of the system cooling (and optional heating) cycles is controlled by the position of the system switch on the room thermostat. Once the system switch is placed in either the **HEAT** or **COOL** position, unit operation is automatic. The optional automatic changeover thermostat, when in the **AUTO** position, automatically changes to heat or cool with sufficient room temperature change.

## Evaporator Fan (Indoor Supply Air)

The evaporator fan is controlled by an **ON/AUTO** switch on the room thermostat. With the switch positioned at **AUTO** and the system operating in the cooling mode, fan operation coincides with the cooling run cycles. If the system is equipped with heat and is operating in the heating mode while the fan switch is at **AUTO**, fan operation coincides with the heating run cycles. When the fan switch is positioned at **ON**, fan operation is continuous.

## Cooling Mode

With the disconnect switch in the **ON** position, current is supplied to the compressor sump heater(s), phase monitor and control transformer. The sump heater(s) supplies heat to the compressor(s) during the “Off” cycle. The phase monitor looks at the incoming power to verify that there is no reversed phase, no phase imbalance, and no loss of phase. If the phase monitor detects any of these three conditions, it will shut off control voltage. The transformer steps down the line voltage to 24V for the low voltage control circuit. When the room thermostat system switch is positioned at **COOL** and the fan switch is at **AUTO**, the compressor contactor energizes on a call for cooling. When the contacts of the compressor contactor close, operation of the compressor and condenser fan begins. The evaporator fan contactor also energizes on a call for cooling and initiates evaporator fan operation.

# Maintenance

## ⚠ WARNING

### Hazardous Voltage w/Capacitors!

Failure to disconnect power and discharge capacitors before servicing could result in death or serious injury.

Disconnect all electric power, including remote disconnects and discharge all motor start/run capacitors before servicing. Follow proper lockout/tagout procedures to ensure the power cannot be inadvertently energized. For variable frequency drives or other energy storing components provided by Trane or others, refer to the appropriate manufacturer's literature for allowable waiting periods for discharge of capacitors. Verify with a CAT III or IV voltmeter rated per NFPA 70E that all capacitors have discharged.

For additional information regarding the safe discharge of capacitors, see *PROD-SVB06\*-EN*.

## NOTICE

### Operating Under Vacuum!

Failure to follow these instructions will result in compressor failure.

Do not operate or apply power to the compressor while under a vacuum.

Perform all of the indicated maintenance procedures at the intervals scheduled. This will prolong the life of the unit and reduce the possibility of costly equipment failure.

## Monthly

Conduct the following maintenance inspections once per month.

- Check unit wiring to ensure all connections are tight and that the wiring insulation is intact.
- Inspect the condenser coils for dirt and debris. If the coils appear dirty, clean them.
- With the unit operating in the cooling mode, check the suction and discharge pressures and compare them with Pressure Curve values in unit Service Facts. Record these readings on the "Maintenance Log," p. 28.

## Annually (Cooling Season)

The following maintenance procedures must be performed at the beginning of each cooling season to ensure efficient unit operation.

- Perform all of the monthly maintenance inspections.
- With the unit operating, check unit superheat and

record the reading in the "Maintenance Log," p. 28.

- Remove any accumulation of dust and/or dirt from the unit casing.
- Remove corrosion from any surface and repaint. Check the gasket around the control panel door to ensure it fits correctly and is in good condition to prevent water leakage.
- Inspect the control panel wiring to ensure that all connections are tight and that the insulation is intact.  
*Note: Condenser fan motors are permanently lubricated.*
- Check refrigerant piping and fittings for leaks
- Inspect the condenser coils for dirt and debris. If the coils appear dirty, clean them.

## Coil Cleaning

Regular coil maintenance, including annual cleaning-enhances the unit's operating efficiency by minimizing:

- compressor head pressure and amperage draw
- water carryover
- fan brake horsepower
- static pressure losses

At least once each year — or more often if the unit is located in a "dirty" environment — clean the coil using the instructions outlined below. Be sure to follow these instructions as closely as possible to avoid damaging the coils.

## Microchannel (MCHE) Coils

### NOTICE

#### Coil Damage!

Failure to follow instructions below could result in coil damage.

**DO NOT use any detergents with microchannel condenser coils.**

**Use pressurized water or air ONLY, with pressure no greater than 600psi.**

*For additional information regarding the proper microchannel coil cleaning procedure, refer to RT-SVB83\*-EN*

Due to the soft material and thin walls of the MCHE coils, the traditional field maintenance method recommended for Round Tube Plate Fin (RTPF) coils does not apply to microchannel coils. Moreover, chemical cleaners are a risk factor to MCHE due to the material of the coil. The manufacturer does not recommend the use of chemical cleaners to clean microchannel coils. Using chemical cleaners could lead to warranty claims being further evaluated for validity and failure analysis.

The recommended cleaning method for microchannel condenser coils is pressurized water or air with a non-pinpoint nozzle and an ECU of at least 180 with pressure no greater than 600 psi. To minimize the risk of coil damage, approach the cleaning of the coil with

the pressure washer aimed perpendicular to the face of the coil during cleaning. Optimum clearance between the sprayer nozzle and the microchannel coil is 1"–3".



# Wiring Diagram Matrix

**Table 4. Wiring schematics R-22 cooling**

Model Number	Ton	Refrigerant Circuit	Voltage	Hz	Ph	Schematics	Connection Diagrams
						Electromechanical	Electromechanical
TTA09023A	7.5	Single	208-230	60	3	12132168	12132181
TTA09024A	7.5	Single	460	60	3	12132168	12132181
TTA12023A	10	Single	208-230	60	3	12132168	12132181
TTA12024A	10	Single	460	60	3	12132168	12132181
TTA18023D	15	Dual	208-230	60	3	12132168	12132184
TTA18024D	15	Dual	460	60	3	12132168	12132184
TTA24023D	20	Dual	208-230	60	3	12132168	12132184
TTA24024D	20	Dual	460	60	3	12132168	12132184

**Note:** Wiring diagrams are available through e-Library or by contacting your local sales office.

# Warranty

## For Commercial Unitary Equipment Rated Under 20 Tons and Related Accessories

**Products Covered** — This warranty is extended by Trane, and applies to the following products:

- All packaged and split system air conditioners and heat pumps have a rated capacity of less than 20 tons.
- All packaged combinations gas/electric air conditioners having a rated capacity of less than 20 tons.
- All packaged combination gas/electric air conditioners having a rated capacity of 1.5 through 5 tons single phase electric power and used for commercial applications. (As used in this warranty, a commercial application is any application where the end purchaser uses the product for other than personal, family or household purposes.)
- All accessories for the above products which are sold by Trane and applied in accordance with Trane specifications.

### Basic Warranty

The warrantor warrants for a period of twelve (12) months from the initial start-up or eighteen (18) months from date of shipment, whichever is sooner, that the products covered by this warranty (1) are free from defects in material and manufacture, and (2) have the capacities and ratings set forth in the warrantor's catalogs and bulletins. If any part of your air conditioner fails because of a manufacturing defect, Warrantor will furnish without charge the required replacement part.

Any local transportation, related service labor and diagnosis calls are not included. In addition, if the sealed motor-compressor fails because of a manufacturing defect within the second through fifth year from the date of original purchase, Warrantor will furnish without charge the required replacement compressor.

### Exclusions and Limitations

The warrantor's obligations and liabilities under this warranty are limited to furnishing F.O.B. factory or warehouse at the warrantor-designated shipping point, freight allowed to Buyer's city (or port of export for shipments outside the conterminous United States) a replacement product or, at the option of the warrantor, parts for the repair of the product not conforming to this warranty and which have been returned to the warrantor.

The warrantor's warranty is conditional on the Customer providing written notice to the warrantor

within thirty (30) days of the discovery of the defect. No product shall be returned to the warrantor without the warrantor's written permission. No liability whatever shall attach to warrantor until said products have been fully paid for and then said liability shall be limited to the purchase price of the equipment shown to be defective.

The warranty does not apply to any compressor or gas-fired heat exchanger which has been repaired or altered in such manner as, in the judgement of the warrantor, affects its stability or reliability. This warranty does not cover (1) any heat exchanger which has been fired with an improper type of fuel (2) a heat exchanger which is installed in a beauty parlor, dry cleaning establishment, de-greasing plant or in any corrosive atmosphere; or (3) any heat exchanger which is not shown to be defective by the warrantor's inspection.

This warranty does not cover damage due to accident, abuse, improper use, external causes, freezing, corrosion, erosion or deterioration. Local transportation, related service labor, air filters, diagnosis calls, refrigerant and related items are not covered.

THE WARRANTY AND LIABILITY SET FORTH HEREIN ARE IN LIEU OF ALL OTHER WARRANTIES AND LIABILITIES, WHETHER IN CONTRACT OR IN NEGLIGENCE, EXPRESS OR IMPLIED, IN LAW OR IN FACT, INCLUDING IMPLIED WARRANTIES OR MERCHANTABILITY AND FITNESS FOR A PARTICULAR PURPOSE AND ANY IMPLIED WARRANTIES OTHERWISE ARISING FROM THE COURSE OF DEALING OR TRADE. IN NO EVENT SHALL THE WARRANTOR BE LIABLE FOR ANY INCIDENTAL OR CONSEQUENTIAL DAMAGES.

The warrantor makes certain further warranty protection available on an optional, extra-cost basis. Any further warranty must be in writing. If you wish further help or information concerning this warranty, contact: Trane — Warrantor, 2701 Wilma Rudolph Blvd., Clarksville, TN 37040

## Commercial Equipment Rated 20 Tons and Larger and Related Accessories (Parts Only)

**Products Covered** — This warranty is extended by Trane, and applies only to commercial equipment rated 20 tons and larger and related accessories purchased and retained for use within the U.S.A. and Canada.

Warrantor warrants for a period of 12 months from initial start-up or 18 months from date of shipment, whichever is less, that the products covered by this warranty (1) are free from defects in material and manufacture, and (2) have the capacities and ratings

set forth in catalogs and bulletins; provided, that no warranty is made against corrosion, erosion or deterioration.

If any part of your air conditioner fails because of a manufacturing defect, Warrantor will furnish without charge the required replacement part.

Any local transportation, related service labor and diagnosis calls are not included. In addition, if the sealed motor-compressor fails because of a manufacturing defect within the second through fifth year from the date of original purchase, Warrantor will furnish without charge the required replacement compressor.

Warrantor's obligations and liabilities under this warranty are limited to furnishing, F.O.B. factory replacement parts (or equipment at the option of Warrantor) for all Warrantor's products not conforming to this warranty. Warrantor shall not be obligated to pay for the cost of lost refrigerant. No liability whatever shall attach to Warrantor until said products have been paid for and then said liability shall be limited to the purchase price of the equipment shown to be defective.

The Warranty and Liability set forth herein are in lieu of all other warranties and liabilities, whether in contract or in negligence, express or implied, in law or in fact, including implied warranties of merchantability and fitness for particular use, and in no event shall warrantor be liable for any incidental or consequential damages

Some states do not allow limitations on how long an implied warranty lasts or do not allow the exclusion or limitation of incidental or consequential damages, so the above limitation or exclusion may not apply to you. This warranty gives you specific legal rights, and you may also have other rights which vary from state to state.

Trane — Warrantor, 2701 Wilma Rudolph Blvd.,  
Clarksville, TN 37040

GW-598-4799

### Exclusions And Limitations

The warrantor's obligations and liabilities under this warranty are limited to furnishing F.O.B. factory or warehouse at the warrantor-designated shipping point, freight allowed to Buyer's city (or port of export for shipments outside the conterminous United States) a

replacement product or, at the option of the warrantor, parts for the repair of the product not conforming to this warranty and which have been returned to the warrantor.

The warrantor's warranty is conditional on the Customer providing written notice to the warrantor within thirty (30) days of the discovery of the defect. No product shall be returned to the warrantor without the warrantor's written permission. No liability whatever shall attach to warrantor until said products have been fully paid for and then said liability shall be limited to the purchase price of the equipment shown to be defective.

The warranty does not apply to any compressor or gas-fired heat exchanger which has been repaired or altered in such manner as, in the judgement of the warrantor, affects its stability or reliability. This warranty does not cover (1) any heat exchanger which has been fired with an improper type of fuel (2) a heat exchanger which is installed in a beauty parlor, dry cleaning establishment, de-greasing plant or in any corrosive atmosphere; or (3) any heat exchanger which is not shown to be defective by the warrantor's inspection.

This warranty does not cover damage due to accident, abuse, improper use, external causes, freezing, corrosion, erosion or deterioration. Local transportation, related service labor, air filters, diagnosis calls, refrigerant and related items are not covered.

THE WARRANTY AND LIABILITY SET FORTH HEREIN ARE IN LIEU OF ALL OTHER WARRANTIES AND LIABILITIES, WHETHER IN CONTRACT OR IN NEGLIGENCE, EXPRESS OR IMPLIED, IN LAW OR IN FACT, INCLUDING IMPLIED WARRANTIES OR MERCHANTABILITY AND FITNESS FOR A PARTICULAR PURPOSE AND ANY IMPLIED WARRANTIES OTHERWISE ARISING FROM THE COURSE OF DEALING OR TRADE. IN NO EVENT SHALL THE WARRANTOR BE LIABLE FOR ANY INCIDENTAL OR CONSEQUENTIAL DAMAGES.

The warrantor makes certain further warranty protection available on an optional, extra-cost basis. Any further warranty must be in writing. If you wish further help or information concerning this warranty, contact: Trane — Warrantor, 2701 Wilma Rudolph Blvd., Clarksville, TN 37040



Ingersoll Rand (NYSE: IR) advances the quality of life by creating comfortable, sustainable and efficient environments. Our people and our family of brands – including Club Car®, Ingersoll Rand®, Thermo King® and Trane® – work together to enhance the quality and comfort of air in homes and buildings; transport and protect food and perishables; and increase industrial productivity and efficiency. We are a global business committed to a world of sustainable progress and enduring results.



[ingersollrand.com](http://ingersollrand.com)

Ingersoll Rand has a policy of continuous product and product data improvements and reserves the right to change design and specifications without notice.  
We are committed to using environmentally conscious print practices.